



# PLACER

## WEIGHT DATA AND SPECS

All weights denote a working load with concrete

Operational Weight:  
**1300 lb.**

Absolute Maximum Weight  
(with concrete) on any single wheel is  
**490 lb.**

A 42 sq. in. tire contact patch gives a  
Working Weight of:  
**11.66 PSI**

NOTE:  
A 5ft. boom can be used to reduce weights

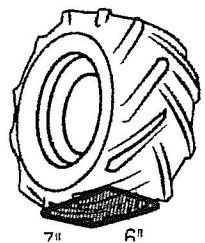

Tire contact patch  
at 15 PSI is 7" w x 6" l

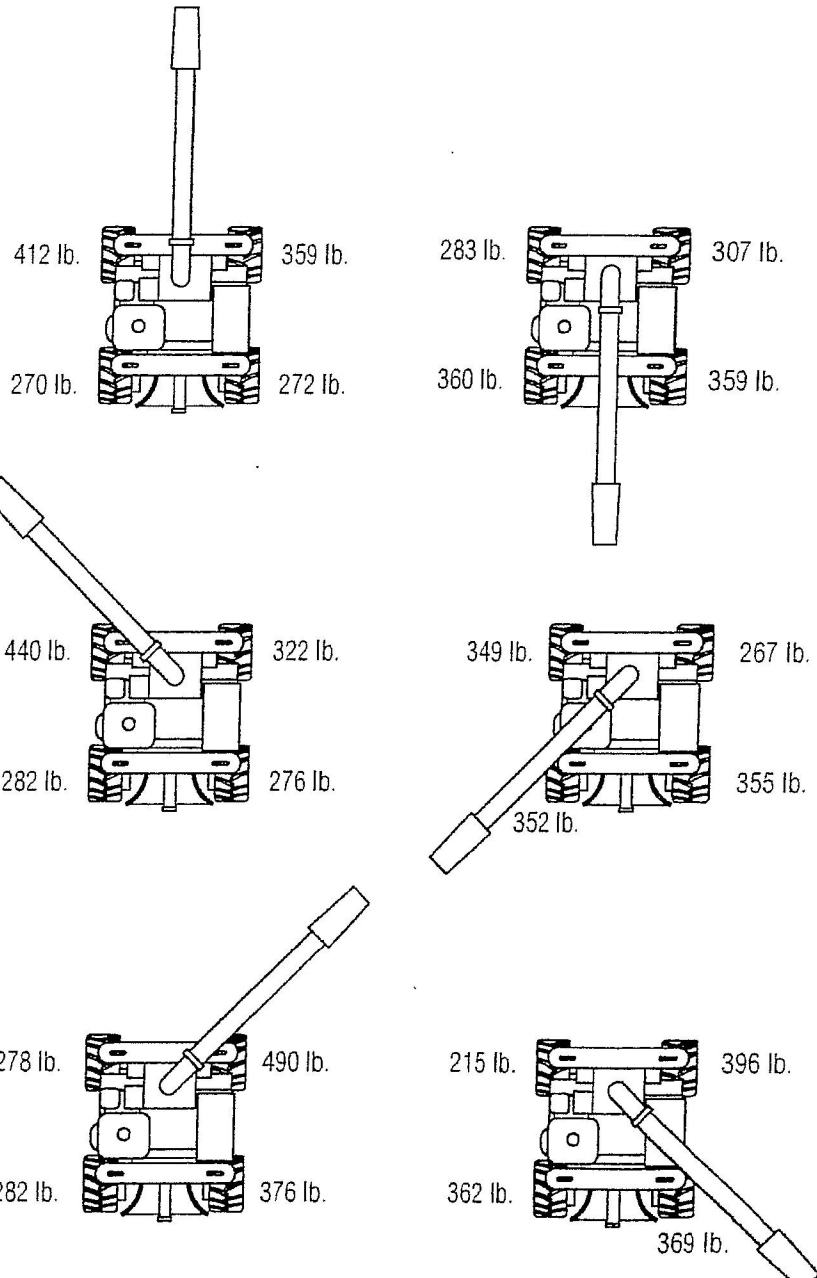
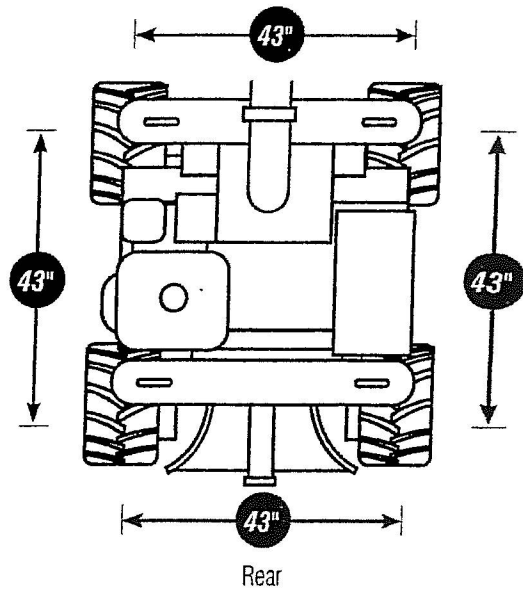

Rear



# DRAGGER

## WEIGHT DATA AND SPECS

All weights denote a working load with concrete

Operational Weight:

**1115 lb.**

Absolute Maximum Weight:  
(with concrete) on any single wheel is

**296 lb.**

A 42 sq. in. tire contact patch gives a  
Working Weight of:

**7.04 PSI**

**NOTE:**

A 5ft. boom can be used to reduce weights

